



The Gas Station Canopy LED series has a beautiful low profile design intended for gas stations and other commercial applications. Ideal for surface mount to hard ceiling or pendant mount from 3/4 NPT conduit. High-performance illumination rated for a minimum of 50,000 hours. It is ideal for replacing a 400W metal halide.

FEATURES

- * Standard in 5000K
- * 100-277V AC input voltage (50-60Hz)
- * 19,500 lumens
- * Philips Lumileds LED chips
- * Premium Mean Well driver
- * Die cast aluminum housing with durable white powder coat finish with at least 2 mils thick on all surfaces and a heat resistant polycarbonate lens
- * Power factor > 0.90
- * Total harmonic distortion <20%
- * Color rendering Index >80
- * Easy installation in new construction or retrofit

MOUNTING OPTIONS

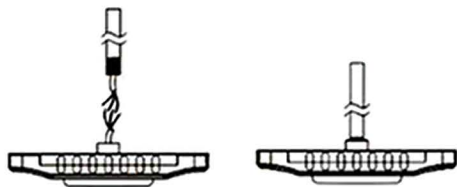

Conduit Pipe Mount

ORDERING INFORMATION

PART #	Color Temp	Lumens	Lumen/watt	Wattage
SZ-CNP150WWAEW-5000K	5000K	19,500	130	150

WARRANTY & DETAILS

- * UL listed
- * DLC Listed
- * IP65 "wet location" rated
- * 5 Yr warranty on all electronics and housing

DIMENSIONS

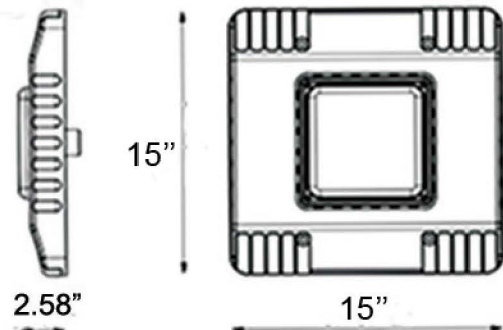

* Standard with support ceiling mount and conduit pipe mount.



PHOTOMETRIC DATA

Luminous Intensity Distribution Curve

